

section **9.1**

**CD V-715-1A+1B  
retrofit victoreen**



## **table of contents**

---

|                                                   |               |
|---------------------------------------------------|---------------|
| <b>Disassembly</b>                                | <b>9.1-1</b>  |
| <b>Coat Transformer</b>                           | <b>9.1-1</b>  |
| <b>Modify Support Post</b>                        | <b>9.1-2</b>  |
| <b>High-Impedance Section Rework</b>              | <b>9.1-2</b>  |
| <b>High- and Low-Impedance Component Cleaning</b> | <b>9.1-3</b>  |
| <b>Positioning of High-Impedance Components</b>   | <b>9.1-4</b>  |
| <b>Preassembly Testing</b>                        | <b>9.1-5</b>  |
| <b>Reassembly Procedure</b>                       | <b>9.1-5</b>  |
| <b>Retrofitted Preassembly</b>                    |               |
| <b>Unretrofitted Preassembly</b>                  |               |
| <b>Unretrofitted Reassembly</b>                   | <b>9.1-6</b>  |
| <b>Precalibration Test</b>                        | <b>9.1-8</b>  |
| <b>Calibration</b>                                | <b>9.1-9</b>  |
| <b>End Retrofit/Test</b>                          | <b>9.1-10</b> |
| <b>Special Instructions</b>                       | <b>9.1-10</b> |
| <b>Materials List</b>                             |               |

## **list of illustrations**

---

|              |                                                             |        |
|--------------|-------------------------------------------------------------|--------|
| Figure 9.1-1 | R-9 on Foil Side of PC Board                                | 9.1-2  |
| Figure 9.1-2 | Positioning Polyethylene Block<br>on Case Top               | 9.1-10 |
| Figure 9.1-3 | Applying DC-5 Compound to Switch<br>Shaft Washer with Brush | 9.1-10 |
| Figure 9.1-4 | Sealing Tube Socket with RTV                                | 9.1-11 |
| Figure 9.1-5 | Installing Ion Chamber Feed-<br>Through Gasket              | 9.1-12 |

CD V-715-1A

LFC

This retrofit procedure is based on extensive engineering studies and tests. Retrofitted instruments are more reliable, accurate, and stable than unretrofitted instruments.

All unretrofitted instruments that State shops process must be retrofitted before they are returned to the field.

Do not deviate from this procedure.

DISASSEMBLY

1. Open the pull catches and remove the instrument from the case bottom. Remove desiccant and save it for reactivation.
2. Remove the four screws that secure the ionization chamber and its grounding spring.
3. Remove the meter-connecting leads at the meter terminals.
4. Remove the zero-control knob. It is unnecessary to remove the range switch knob.
5. Remove the two screws securing the battery box to the instrument top. Swing the battery box away from the PC board.
6. Remove the other screws holding the PC board to the case top. Remove the PC board by pressing on the zero-control shaft and by pulling lightly on the PC board.
7. Remove the range switch drive shaft from the circuit-shield box.
8. Remove the two screws holding the circuit-shield box to the PC board, and remove the circuit-shield box.
9. Remove and discard the shield box sponge rubber gasket.
10. Remove the rubber-pressure block on the PC board.

COAT TRANSFORMER

Apply a coat of polystyrene Q-Dope (GC No. 37-2) or waterproofing varnish (FSN-8010-298-3870) to the high-voltage windings of the transformer. This coating will tend to preclude accidental damage to the windings during subsequent processing of the PC board.

CD V-715-1A & 1BVictoreenMODIFY SUPPORT POST

Measure 1/4 inch from case top. Mill, file, or grind a shallow notch approximately 1/8 inch deep and 1/2 inch long in the X1 side of the chassis-support post so that the adjustment screwdriver of the CD V-794 Model 2 calibrator can have access to the X1 potentiometer. A notch approximately 1/8 inch deep x 1/2 inch long will permit alignment when pots are replaced. It will also permit alignment should the case tops and PC boards be mixed up during retrofit. Do not shorten or remove the support post.

HIGH-IMPEDANCE SECTION REWORK

1. Remove resistor R-9 and visually inspect it. If color-coded 470K ohms, replace with a 680K-ohm resistor. Install replacement 680K-ohm resistor with resistor body on the foil side of the PC board. Do not solder resistor lead to the guard ring connection on the PC board. This step will be accomplished later (see Figure 9.1-1).

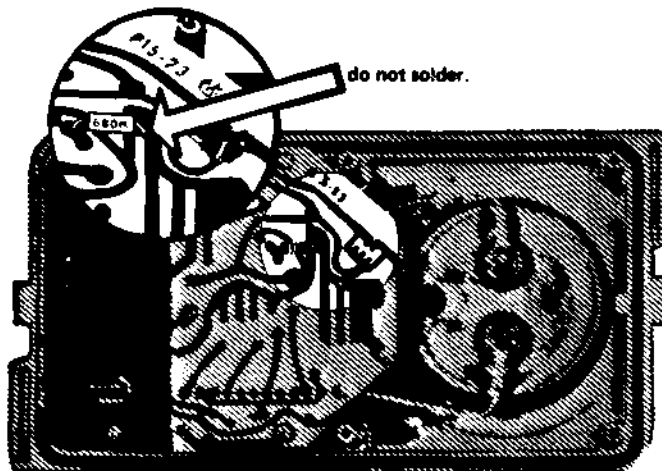

Figure 9.1-1. R-9 on Foil Side of PC Board

CD V-715-1A & 1BVictoreen

2. Remove all high megs. If X.1 resistor is glass ( $10^{11}$ ), measure resistance. Glass high megs with values within the range of  $2.0 \times 10^{11}$  ohms to  $2.60 \times 10^{11}$  ohms will be retained for reinstallation in the instrument. Place glass high megs outside the range of 2.0 to  $2.60 \times 10^{11}$  ohms in segregated storage.
3. When installing the glass high megs, position them in the same manner as the resistor that was installed in the X.1 position. Install the glass high megs (four different ranges) as follows:
  - The X1 range high meg uses the same mounting hole in the board as the X.1 resistor. Open the hole with a soldering pencil and soldering aid to make room for the lead of both resistors. Solder resistors in place on the PC board and on the appropriate switch lugs.
  - The X10 and X100 range resistors are mounted in similar fashion on the opposite side of the switch stator from the X1 and X1 resistors. The low-side (guard-ring side) leads of these resistors are connected to the same mounting hole in the board used by the guard-ring side of resistor R9. Open the hole with a soldering pencil and soldering aid to make room for both leads, but do not remove the R9 lead. Solder high meg resistors in place on the appropriate switch lugs. Solder remaining high meg leads and R9 and the PC board.

HIGH- AND LOW-IMPEDANCE COMPONENT CLEANING

**WARNING:** Methanol, methyl alcohol ( $\text{CH}_3\text{OH}$ ) and, to a certain extent, isopropanol, 2-propanol, isopropyl alcohol ( $\text{CH}_3\text{CH}_2\text{CH}_2\text{OH}$ ) are considered moderately toxic hazards under conditions of continuous exposure. Exposure over extended periods of time to fumes or to the liquid itself by inhalation, absorption through the skin, or ingestion could

CD V-715-1A & 1BVictoreen

cause severe injury to the eyes and the nervous system. In addition, they can both become fire hazards when exposed to excessive heat or flame. In terms of a fume hazard and ingested poison, methanol is about twice as hazardous as isopropanol. The skin absorption hazard of both these materials is about the same.

You must clean in a well-ventilated area, preferably with a fume hood and away from open flames or from a smoking area.

1. Number three suitable containers 1, 2, and 3. Number two stencil brushes 1 and 3; number an oval brush 2. Place the three sets of brushes and containers in the designated cleaning area. Pour sufficient methanol in each container for the projected load to be completed by the end of the work period.
2. Using surgeons' or rubber gloves, dip stencil brush no. 1 into the no. 1 container of alcohol. Scrub only the foil side of the phenolic PC board, allowing the alcohol to run off the board as waste into a sink or basin.
3. Dip the oval brush no. 2 into the no. 2 container of alcohol. Scrub only the component side of the phenolic PC board, allowing the alcohol to run off the board as waste into a sink or basin.



CD V-715-1A & 1BVictoreen

4. Dip the stencil brush no. 3 into the no. 3 container of alcohol. Scrub only the glass high megs, ceramic switch, and glass envelope of the electrometer tube, allowing the alcohol to run off the board as waste into a sink or basin.

Note: When additional alcohol is required, pour alcohol remaining in no. 3 container into containers 1 or 2. Each time you need additional alcohol, empty no. 3 container and rinse it with a small amount of clean alcohol. Never pour used alcohol back into unused stock.

5. Immediately after doing the above, spray switch, high megs, tube, calibration, and zero potentiometers with a two- to three-second burst of Miller-Stephenson MS-180 Freon TF Degreaser.
6. Position ion chamber with the insulator pointing down and spray ion chamber insulator with about a two- to three-second burst of Miller-Stephenson MS-180 Freon TF Degreaser.
7. Dry the PC board and the ion chamber in a ventilated oven at 150° F for 15 to 20 minutes or at 130° F for 25 to 30 minutes. (Position the chamber in the oven with the insulator pointing down.)
8. Remove PC board and ion chamber from oven and allow instrument to cool off for 20 minutes before proceeding.

CD V-715-1A & 1BVictoreenPOSITIONING OF HIGH-IMPEDANCE COMPONENTS

**CAUTION:** During the following steps, avoid touching the switch wafer, electro-meter tube, and high meg bodies as much as possible. Use clean tweezers, needle-nose pliers, or forceps to manipulate components.

Position the high megs and tube with the aid of a "see-through dust cover," as follows:

1. Place the dust cover in proper position over the high-impedance section, insert plastic switch shaft through the dust cover, and engage switch rotor.
2. Arrange position of high megs so that these components and their leads do not touch the dust cover, switch, or switch shaft.
3. Arrange the position of the tube-grid lead so that it does not touch any of the resistors, dust cover, or switch.
4. Remove the "see-through dust cover."
5. Apply a light coating of DC-5 Silicone Compound to the base of the electrometer tube. Use a small, clean artist's brush for this operation to prevent contaminating the tube.

PREASSEMBLY TESTING

1. Install a special solid dust cover with plastic shaft and switch index board.
2. Connect meter to the board meter terminals with test leads.

CD V-715-1A & 1BVictoreen

3. Install mercury battery.
4. Set instrument switch to "ZERO" position and allow approximately two minutes to warm up.
5. Adjust zero control until meter reads zero.
6. Turn switch to "CIRCUIT CHECK" and hold. (Meter should read above 35 divisions.)
7. Turn instrument switch to each switch position X100, X10, X1, and X.1. Without the presence of radiation, the meter should indicate basically zero. During this test, instruments that read in excess of  $\pm 2$  minor meter divisions on the X.1 range or  $\pm 1$  on the other ranges will require recleaning and/or repair.
8. Remove battery.

Note: Technicians may discontinue "Preassembly Testing" when they gain confidence in cleaning techniques and when rejects are minimal.

REASSEMBLY PROCEDURERetrofitted Preassembly

Note: The following steps are for instruments that have been previously retrofitted and require disassembly for repair. Skip these steps for instruments not previously retrofitted. Proceed to "Unretrofitted Assembly."

CD V-715-1A & 1BVictoreen

This procedure requires use of a polyethylene block, Sort Code 21374, designed to a thickness to create pressure on the high-impedance circuit dust cover. The pressure will eliminate warpage around the dust-cover gasket seating area caused by the chamber feed-through gasket. It will provide for a good seal between the dust-cover gasket and the PC board. During the reassembly process, the PC board will be sprung approximately 1/4-inch, creating a gap between the PC board and the instrument-chassis post. By applying a small amount of pressure, the technician can easily affix the PC board to the chassis.

The polyethylene block must be used as furnished. Do not modify it.

With the dust-cover gasket, use a dag coating to facilitate grounding of the dust cover. Therefore, you no longer need the original ground wire from the ceramic switch and should remove it.

- a. Remove as much as possible of the DC-5 silicone grease from the dust cover and PC board with tissue paper.

CD V-715-1A & 1BVictoreen

- b. Clean the PC board and high-impedance area as outlined in "High- and Low-Impedance Component Cleaning."
- c. Wash dust cover in liquid detergent and rinse with water. Spray with Freon Degreaser and allow to dry.
- d. Reapply dag to inside of dust cover. Ensure that some dag runs into the dust cover screw mounting holes. Allow to dry.

Unretrofitted Reassembly

- a. Apply a small amount of dag in each of the two screw mounting holes of the dust cover. Ensure that the applied dag connects with the manufacturer's dag coating inside the dust cover. Allow to dry.
- b. Position the new dust-cover gasket (Sort Code 21373) onto the dust cover and apply a very light coating of DC-5 to the bottom of the gasket with a brush. Mount the cover to the PC board using 4-40 x 3/8" machine screws (Sort Code 22196).
- c. Remove protective paper from one side the polyethylene foam block (Sort Code 21374) that measures 1" x 2". Position this block on the case top as shown in figure 9.1-2 with the adhesive side down.

CD V-715-1A & 1BVictoreen

Figure 9.1-2 Positioning Polyethylene Block on Case Top

3. Apply a light coating of DC-5 compound with a brush to the switch shaft composition washer as shown in figure 9.1-3. If the black composition washer is damaged or lost, use a film of DC-5 as a replacement.

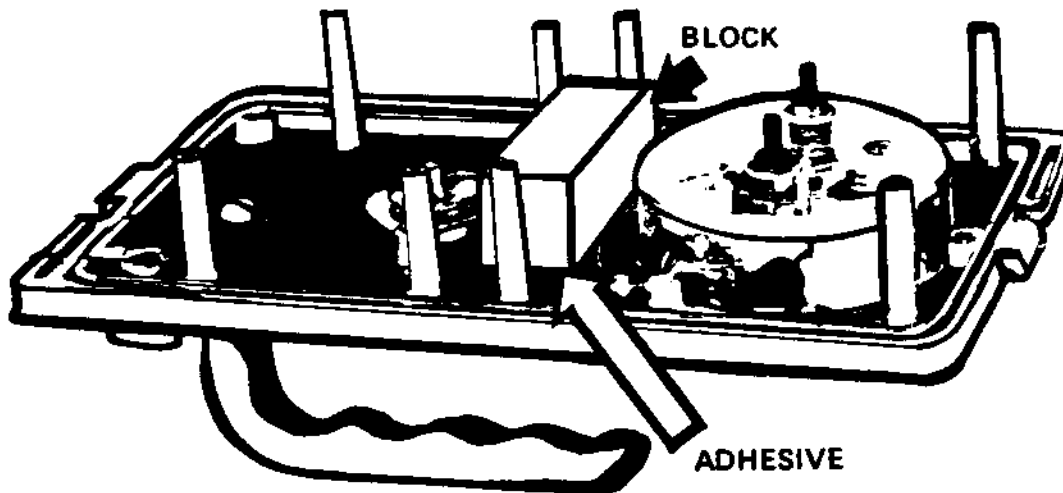
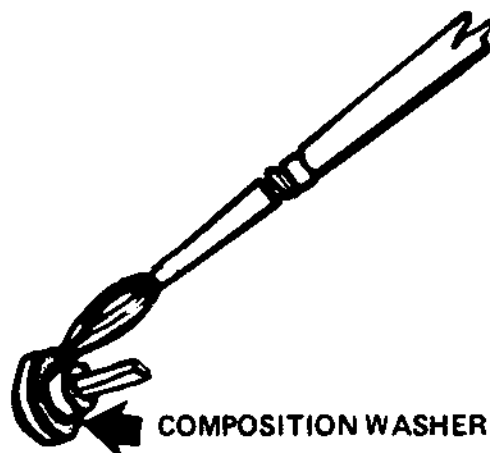

Figure 9.1-3. Applying DC-5 Compound to Switch Shaft Washer with Brush

CD V-715-1A & 1B

Victoreen

4. Insert switch shaft into dust cover and engage switch rotor. Seat switch shaft by applying light pressure.
5. Apply a light coating of DC-5 to zero control "O" ring.
6. Seal the tube socket with a coating of RTV Adhesive (Sort Code 21375) as shown in figure 9.1-4.

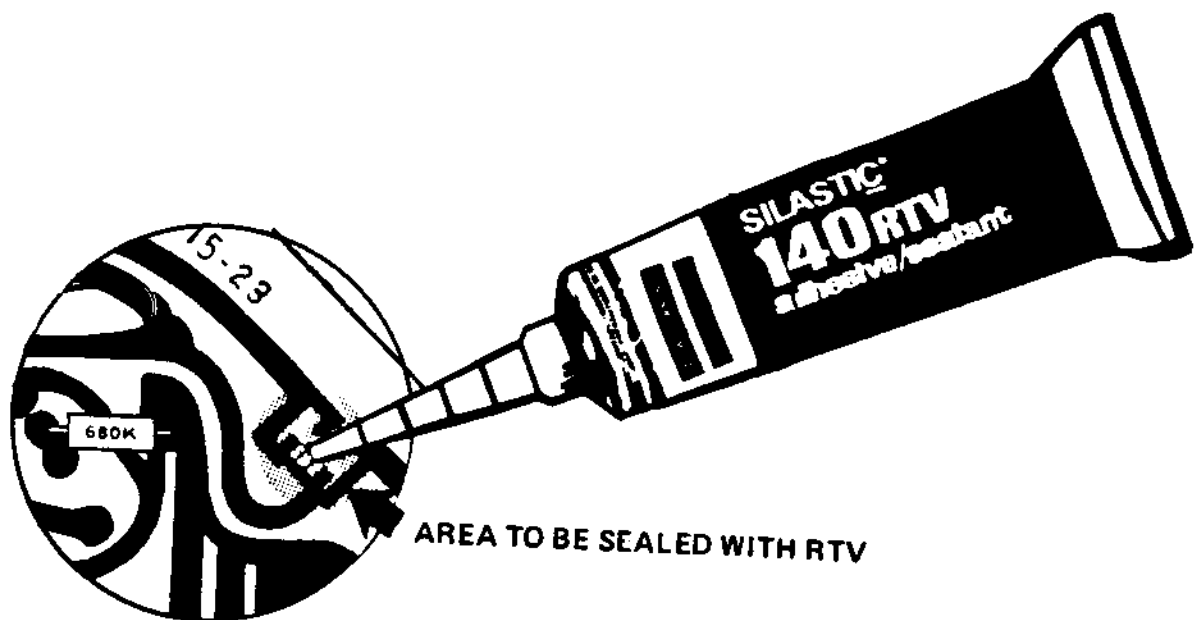

Figure 9.1-4. Sealing Tube Socket with RTV

CD V-715-1A & 1BVictoreen

7. Install spring on chamber guard ring.
8. Apply light coating of DC-5 compound to ion chamber feed-through gasket (Sort Code 21410). Place a gasket over ion chamber feed-through (see figure 9.1-5).

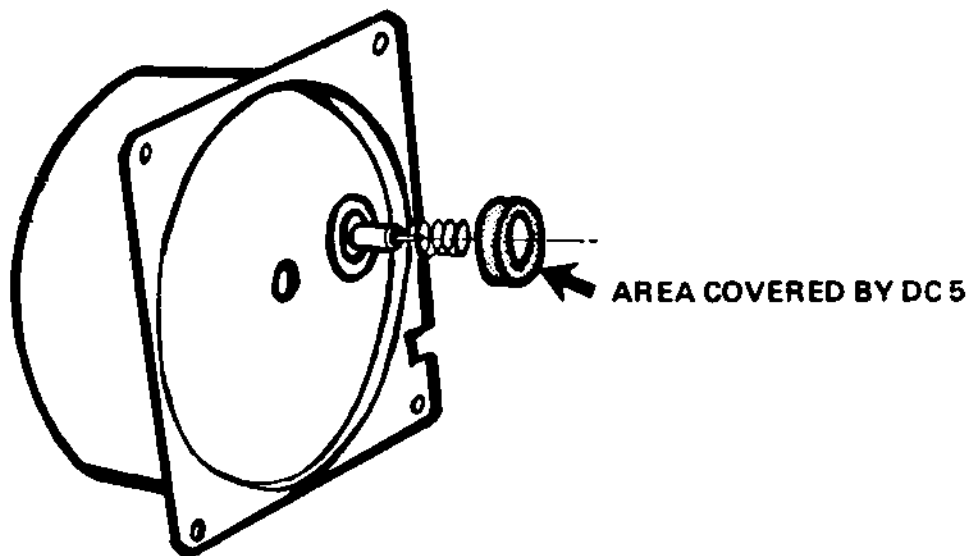

Figure 9.1-5. Installing Ion Chamber Feed-Through Gasket

9. Install ion chamber and zero control knob.
10. Using the rubber stamp and ink, mark the PC board with an "R" on the foil side between the battery compartment and the ion chamber. Black marking ink is preferred.



CD V-715-1A & 1BVictoreenPRECALIBRATION TEST

1. Install "D" cell battery in the instrument.  
Note: You may use old kit batteries or any battery with a terminal voltage  $> 1.2$  V under load.
2. Turn instrument range switch "OFF" to "ZERO" position and allow electrometer tube to "age in" for at least 16 hours.
3. Remove "D" cell and install a mercury battery in the instrument. Allow a five-minute warmup.
4. Adjust zero control until meter reads zero.
5. Turn switch to "CIRCUIT CHECK" and hold. (Meter should read above 35 meter divisions.)
6. Turn instrument switch to read switch position X100, X10, X1, and X.1. Without the presence of radiation, the meter should indicate basically zero. During this test, instruments that read in excess of  $\pm 2$  minor meter divisions on the X.1 range or  $\pm 1$  on the other ranges will require recleaning and/or repair.

CALIBRATION

1. Use the CD V-794 Model 2 Calibrator to calibrate the instrument on each range to within  $\pm 1$  minor scale division of the desired reading.

Important Note: Repair is necessary if:

- The instrument cannot be calibrated as indicated above.

CD V-715-1A & 1BVictoreen

- One or more calibration potentiometers will not adjust to two or more minor meter scale divisions above the calibration desired. In practice, this is tested by rotating the calibration potentiometers fully clockwise and rotating back to the calibration point. This requirement is only for the initial calibration of a retrofitted instrument. Retrofitted instruments recycled through the shop for recalibration, maintenance, and readiness and reliability ensurance tests do not have to meet this requirement.

2. Remove instrument from the calibrator.
3. Remove the mercury battery and install a good "D" cell and repeat Steps 5 and 6 under "Precalibration Test."

Note: Perform all future calibrations of these instruments using a mercury cell.

4. Switch instrument to X.1 range and place in CD V-794 calibrator. Turn calibrator exposure wheel to 0.4 R/hr position and observe the instrument response for stability (does not exhibit windshield wiping or tic-toc).

Important Note: Instruments exhibiting instabilities are normally repaired by replacing transistor Q1 with a transistor of lower gain (Sort Code 22207). Whenever you replace a transistor in an instrument, test it for compatibility by monitoring the electrometer tube plate voltage while actuating the "circuit check" function. Use a high-impedance (>10 megohms) voltmeter

CD V-715-1A & 1BVictoreen

with the negative lead connected to the battery minus. When the "circuit check" is actuated, the plate voltage must drop off by at least 0.2V but no more than 0.4V. If the plate voltage does not drop off by  $>0.2V$ , install a lower gain transistor (prevents tic-toc). If the plate voltage drops off  $>0.4V$ , install a high-gain transistor. State M&C Shops should short their transistor stocks using the procedure outlined in Appendix D, page D-26, in groups of beta gain by units of 20 over a range of 100 to 400. Test all Victoreen CD V-715 and CD V-717 transistors removed from instruments and place them in the appropriate groups for future use in another instrument. After repair, repeat "Precalibration Test" and "Calibration" steps.

END RETROFIT/TEST

1. Remove battery.
2. Using a small artist's brush, apply a light coating of D-5 compound to the instrument case top gasket. Do not use the brush that coats the gasket on or around the high-impedance circuit.
3. Place reactivated desiccant in instrument's case bottom and immediately reassemble instrument.
4. Mark the exterior of the case top with an "R" after "CD V-715." Use black marking ink. Allow ink to dry, and spray a coating of clear lacquer on the letter "R" and on the immediate area.

CD V-715-1A& 1BVictoreenSPECIAL INSTRUCTIONS

1. Perform only authorized repairs during this procedure.
2. Limit parts replacement to values specified in this Manual.
3. Use only resistors or capacitors of prescribed values during replacement.
4. During replacement of electrometer tubes, replace tube socket if defective electrometer tube leads are soldered in socket. Also, any new tube installed must be "aged in" for 16 hours (see "Precalibration Test," 1 and 2).
5. You can reactivate the desiccant authorized and furnished for use in FEMA radiological instruments. Run new or used desiccant through this reactivation process before placing it in an instrument. The reactivation process is as follows:
  - Heat oven to 250° F.
  - Spread desiccant out in oven or widely space it on the shelves to expose it to as much air as possible.
  - Heat desiccant for 12 to 16 hours.
  - Remove desiccant and place it immediately in a sealed, air-tight container.

You can repeat this reactivation process many times without significantly affecting the efficiency of the desiccant. Because you can significantly degrade the effectiveness of the desiccant by exposing it to the atmosphere, you must reactivate desiccant that has been unused for seven days after it was removed from the oven. Even if the shop is air-conditioned, it is not sufficiently dry to prevent the desiccant from absorbing a significant amount of moisture. Therefore, follow this reactivation process when using desiccant at both the Federal depots and the State M&C Shops.

CD V-715-1A & 1BVictoreen

Table 9.1-1. List of Materials

| Sort Code | Description                                                                                | Unit of Issue |
|-----------|--------------------------------------------------------------------------------------------|---------------|
| 21392     | Resistor X.1                                                                               | Each          |
| 21393     | Resistor X1                                                                                | Each          |
| 21394     | Resistor X10                                                                               | Each          |
| 21395     | Resistor X100                                                                              | Each          |
| 21410     | Gasket (Ion Chamber Feed-Through)<br>500 per box                                           | Box           |
| 22182     | Gloves--Rubber, neoprene, size 10                                                          | Pair          |
| 22183     | Brush--Round, 1 1/16" x 1 1/16", long-<br>handled stencil type                             | Each          |
| 22184     | Brush--Oval style, 1 1/8" x 2 5/8"                                                         | Each          |
| 22185     | Battery--Mercury, 1.35V                                                                    | Each          |
| 22188     | Solvent--Degreaser, freon TF, Miller-<br>Stephenson MS-180, 16 oz. spray can               | Can           |
| 22189     | Compound--Silicone DC-5, 8 oz. tube                                                        | Tube          |
| 22192     | Alcohol--Methyl, electronic grade, 5 gals.<br>(replaces 22181, 1 gal. can)                 | Drum          |
| 22194     | Varnish--FSN 8010-298-3870 (for water-<br>proofing transformer, replaces 22186,<br>Q-Dope) | Can           |
| 22196     | Machine Screw (for circuit-shield box)--<br>4-40 x 3/8"--100 per box                       | Box           |
| 22197     | Lacquer--Clear spray                                                                       | Can           |
| 21373     | Gasket--Dust cover                                                                         | Each          |
| 21375     | 140 RTV, Adhesive--Silicone rubber, paste<br>form, 5 oz. tube, FSN 8040-701-9546           | Tube          |
| None      | Dag--FEMA/ACC EMSTF Issue                                                                  | Jar           |
| 21374     | Block--Polyethylene, adhesive backing,<br>100 per box                                      | Box           |

Hello!

If you are viewing this document on a CD purchased from an ebay seller you could have downloaded it for **FREE** at

[www.civildefensemuseum.com](http://www.civildefensemuseum.com)

Just thought you might like to know where this seller is getting their material.

Thanks

Eric Green

The Civil Defense Museum